

## ON THE CAUSATIVE PARADOXES: DERIVATIONS AND TRANSFER DOMAINS\*

Mamoru Saito  
Nanzan University

### 1. Introduction

Japanese causative sentences look on the surface like simple sentences without embedding. For example, the predicate of (1) is the compound verb, *tabe-sase* ‘eat-cause’.

- (1) Hanako-ga Taroo-ni wani-o tabe-sase-ta  
Hanako-NOM Taroo-DAT alligator-ACC eat-cause-Past

‘Hanako made Taroo eat alligator meat.’

However, it is assumed since Kuroda (1965) that the causative morpheme *-sase-* takes a clausal complement in syntactic structure. Murasugi and Hashimoto (2004), for example, update this analysis and propose that it takes a small clause *v*P complement as in (2).

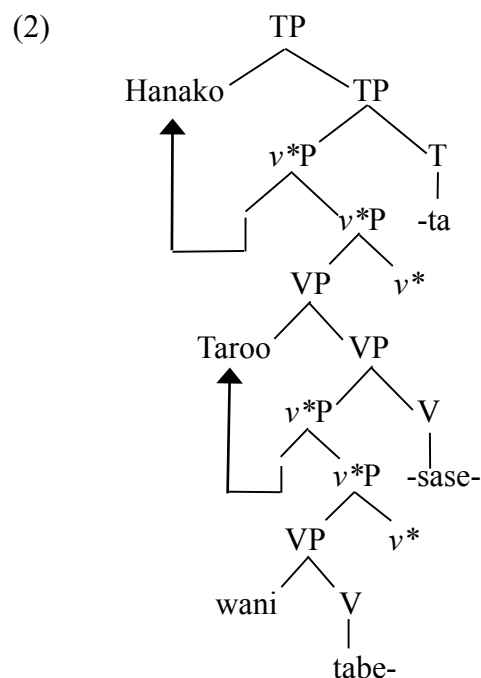

\* The material in this paper was presented in seminars at Keio University and the University of Connecticut. I would like to thank the audiences there and Noam Chomsky for valuable comments. The research leading to the completion of this paper was supported in part by the JSPS Grant-in-Aid for Scientific Research (C) #16K02647 and the Nanzan University Pache Research Subsidy I-A-2 (2019).



If this is correct, (1) has exactly the same structure as its English counterpart in (3), aside from linear order.

(3) Mary made John eat alligator meat

Many pieces of evidence have been presented in the literature in support of the analysis of Japanese causatives with complex structure. At the same time, there are phenomena in which causative sentences pattern with simple sentences without embedding. One of them has to do with Case. Kuno (1973) observes that causative sentences can have only one accusative argument. The causee can accompany accusative Case only if the embedded verb does not take an accusative argument, as shown in (4).

(4) a. Hanako-ga Taroo-ni/-o odor-ase-ta (koto)  
 Hanako-NOM Taroo-DAT/-ACC dance-cause-Past fact  
 ‘Hanako made Taroo dance.’

b. Hanako-ga Taroo-ni/\*-o wani-o tabe-sase-ta (koto)  
 Hanako-NOM Taroo-DAT/-ACC alligator-ACC eat-cause-Past fact  
 ‘Hanako made Taroo eat alligator meat.’

This is surprising if Japanese causatives have the structure in (2). English causatives indeed can have both the causee and the embedded object in accusative, as shown in (5).

(5) Mary made them recommend him

Kato (2016) points out that causative sentences pattern with simple sentences with respect to anaphor binding as well. As observed in Nakamura (1986), *zibun-zisin* ‘self-self’ is an anaphor that requires a local antecedent. Thus, only *Hanako* can be its antecedent in (6a).

(6) a. Taroo-ga [<sub>CP</sub> Hanako-ga zibun-zisin-o suisensi-ta to] omot-te i-ru  
 Taroo-NOM Hanako-NOM self-self-ACC nominate-Past that think-Pres.  
 (koto)  
 fact  
 ‘Lit. Taroo thinks that Hanako nominated self.’ (zibun-zisin = Hanako)

b. Taroo-ga Hanako-ni zibun-zisin-o suisens-ase-ta (koto)  
 Taroo-NOM Hanako-DAT self-self-ACC nominate-make-Past fact  
 ‘Lit. Taroo made Hanako nominate self.’ (zibun-zisin = Taroo or Hanako)

On the other hand, in the causative (6b), both *Taroo* and *Hanako* qualify as the antecedent of *zibun-zisin*. This too is puzzling. In the English counterpart of (6b) in (7), *Bill* is the only possible antecedent of *himself*.

- (7) John made Bill nominate himself (himself = Bill)

The purpose of this paper is to suggest an analysis for (4b) and (6b) on the assumption that (2) is basically the correct structure of Japanese causatives. For the single accusative effect instantiated by (4b), I rely on the proposal in Epstein, Kitahara and Seely (2016) and Nomura (2018) that pair-merge of two heads can apply as in  $\langle H_1, H_2 \rangle$  before they enter into a larger structure. More specifically, I suggest that the causative *-sase-* combines with the embedded  $v^{(*)}$  and enter the larger derivation as  $\langle \text{cause}, v^{(*)} \rangle$ . Put differently,  $\langle \text{cause}, v^{(*)} \rangle$  assigns the causee role and the external  $\theta$ -role to a single argument and is lexicalized as *-sase-*. I show that the single accusative effect follows as a consequence of this analysis. For the apparent extension of the binding domain in (6b), I argue that it follows from Quicoli's (2008) account for Condition A effects in terms of phases when it is combined with the proposal in Saito (2017) that phases are defined differently depending on the presence/absence of  $\phi$ -feature agreement.

Before I present the analysis, I briefly go over the evidence for the structure in (2) in the following section. In Section 3, I discuss the locality of anaphor binding in (6) in comparison with the locality of NP-movement, and suggest a phase-based analysis along the lines of Quicoli (2008). In Section 4, I introduce Epstein, Kitahara and Seely's (2016) argument for head-head pair-merge and present an analysis for the single accusative effect in Japanese causatives. Section 5 concludes the paper.

## 2. Evidence for Complex Structure

As noted above, many pieces of evidence have been presented in the literature for the complex structure of Japanese causative sentences. I go over the arguments based on the interpretation of *zibun*, the locality of NP-movement, the interpretation of adverbs, and Condition B effects in this section.

The best-known evidence, discussed in Kuno (1973), for the complex structure is that the causee in causative sentences can be the antecedent of the subject-oriented reflexive, *zibun*. (8) shows that the antecedent of *zibun* need not be local but must be a subject.

- (8) Hanako-ga [<sub>CP</sub> Taroo-ga Ziroo-ni zibun-no syasin-o mise-ta to]  
 Hanako-NOM Taroo-NOM Ziroo-DAT self-GEN picture-ACC show-Past that  
 it-ta (koto)  
 say-Past fact

'Lit. Hanako said that Taroo showed Ziroo self's picture.' (*zibun* = Hanako or Taroo)

The dative argument *Ziroo* locally c-commands *zibun* but cannot be its antecedent in this example. However, the dative causee argument in causative sentences qualifies as the antecedent of *zibun*, as shown in (9).

- (9) *Hanako-ga Taroo-ni zibun-no syasin-o sute-sase-ta*  
 Hanako-NOM Taroo-DAT self-GEN picture-ACC discard-cause-Past

‘Lit. Hanako made Taroo discard self’s picture.’ (zibun = Hanako or Taroo)

This is accounted for if *Taroo* in (9) originates in the embedded *v*\*P Spec, as in (2), and this position counts as a subject position.

Another piece of evidence is presented in Shibatani (1976). He demonstrates that there is ambiguity with adverb interpretation in causative sentences, which is not observed in simple sentences. There is a clear contrast between the following two examples:

- (10) a. *Hanako-ga Taroo-o isoide rondon-ni hakensi-ta (koto)*  
 Hanako-NOM Taroo-ACC in.a.hurry London-to dispatch-Past fact

‘Hanako dispatched Taroo to London in a hurry.’

- b. *Hanako-ga Taroo-o isoide rondon-ni mukaw-ase-ta (koto)*  
 Hanako-NOM Taroo-ACC in.a.hurry London-to head-cause-Past fact

‘Hanako made Taroo head to London in a hurry.’ (ambiguous)

In (10a), *isoide* ‘in a hurry’ modifies Hanako’s action. On the other hand, (10b) is ambiguous. The adverb can modify Hanako’s action as in (10a) but it can also modify Taroo’s action of heading to London. This is predicted by the structure in (2) with two *v*\*Ps.

The third piece of evidence is due to Inoue (1976). She points out that causative sentences exhibit different patterns from regular ditransitive sentences with respect to passive. As shown in (11), the accusative object in a ditransitive sentence can raise to the subject position in its passive counterpart.

- (11) a. *Hanako-ga Taroo-ni sono hon-o watasi-ta*  
 Hanako-NOM Taroo-DAT that book-ACC hand-Past

‘Hanako handed the book to Taroo.’

- b. *Sono hon-ga Hanako-niyotte Taroo-ni \_ watas-are-ta*  
 that book-NOM Hanako-by Taroo-DAT hand-Passive-Past

‘The book was handed to Taroo by Hanako.’

On the other hand, the passive counterpart of (1) does not allow the accusative object to move to the subject position. (12) is completely ungrammatical.

- (12) \**Wani-ga Hanako-niyotte Taroo-ni \_ tabe-sase-rare-ta*  
 alligator-NOM Hanako-by Taroo-DAT eat-make-Passive-Past

‘Lit. Alligator meat is such that Hanako made Taroo eat it.’

As discussed in more detail below, this is expected if (1) has the structure in (2) with an embedded  $v^*P$ .

Finally, Oshima (1979) shows that causative sentences differ from regular ditransitive sentences with respect to Condition B effects as well. The following pair illustrates the difference.

- (13) a. Taroo-ga kare-o suisensi-ta (koto) (Taroo ≠ kare)  
 Taroo-NOM he-ACC nominate-Past fact  
 ‘Taroo nominated him.’
- b. Taroo-ga Hanako-ni kare-o suisens-ase-ta (koto) (Taroo = kare, ok)  
 Taroo-NOM Hanako-DAT he-ACC nominate-cause-Past fact  
 ‘Taroo made Hanako nominate him.’

In (13a), *Taroo* and *kare* are disjoint in reference, a typical Condition B effect. On the other hand, *kare* can refer to *Taroo* in (13b). As Oshima points out, this is expected if Japanese causative sentences have complex structure.

It was shown in this section that Japanese causative sentences have complex structure as in (2). This makes the single accusative effect in (4) and the binding fact in (6) all the more mysterious. I take up these in the subsequent sections, starting with the latter.

### 3. Phases and Transfer Domains in Causative Sentences

Anaphor binding and NP-movement exhibit different locality in causative sentences. The relevant examples, (6b) and (12) are repeated below in (14a) and (14b) respectively.

- (14) a. Taroo-ga Hanako-ni zibun-zisin-o suisens-ase-ta (koto)  
 Taroo-NOM Hanako-DAT self-self-ACC nominate-make-Past fact  
 ‘Lit. Taroo made Hanako nominate self.’ (zibun-zisin = Taroo or Hanako)
- b. \*Wani-ga Hanako-niyotte Taroo-ni tabe-sase-rare-ta  
 alligator-NOM Hanako-by Taroo-DAT eat-make-Passive-Past  
 ‘Lit. Alligator meat is such that Hanako made Taroo eat it.’

In (14a), the matrix subject qualifies as the antecedent of the local anaphor in the embedded object position. (14b) shows that a noun phrase cannot move from the embedded object position to the matrix subject position. As the theory of phase and transfer is designed to explain locality requirements, I briefly go over its developments in Section 3.1. I first introduce Chomsky’s (2000, 2008) standard theory and its application to anaphor binding by Quicoli (2008). Then, I discuss the modification of the theory proposed in Saito (2017). In Section 3.2,

I show how the contrast in (14) is explained by the theory.

### 3.1. On the Theory of Phase and Transfer

Chomsky (2000) proposes that derivation proceeds phase by phase, where CP and v\*P constitute phases, and that the complement of a phase head is transferred to the interpretive components upon the completion of the phase. This accounts for the locality of NP-movement, as the following example of super-raising illustrates:

(15) \*John seems <sub>[CP that</sub> <sub>[TP it is likely</sub> <sub>[TP \_ to win the race]]]</sub>

When the embedded CP is constructed, the shaded TP, containing *John*, is transferred to the interpretive components. Hence, *John* is unable to move out of this TP to the matrix subject position.

This theory also explains why Wh-movement takes place successive-cyclically. As discussed in Chomsky (1986), Wh-movement proceeds through the edges of CP and v\*P, as illustrated in (16).

(16) [<sub>CP What</sub> [<sub>CP do</sub> [<sub>TP you</sub> [<sub>v\*P \_</sub> [<sub>v\*P think</sub> [<sub>CP \_</sub> [<sub>CP that</sub> [<sub>TP John</sub> [<sub>v\*P \_</sub> [<sub>v\*P bought</sub> \_ ]]]]]]]]]]]]]]



The first step of the movement, for example, is necessary because the embedded VP is transferred to the interfaces upon the completion of the embedded v\*P and hence, the Wh-phrase must move out of the VP before this transfer applies.

Quicoli (2008), among others, has proposed to explain the locality of anaphor binding on the basis of this theory of phase and transfer. His proposal is shown in (17).

(17) Information on the reference of an anaphor is sent to the C-I interface together with the transfer domain containing the anaphor.

I illustrate this proposal with the examples in (18).

(18) a. John recommended himself  
 b. \*John thinks that Mary recommended himself

When the v\*P of (18a) is formed as in (19), the complement VP containing *himself* is transferred to the C-I interface.

(19) [<sub>v\*P John</sub> [<sub>v\*</sub> [<sub>VP recommend himself</sub>]]]

Since *John* is already in the structure and c-commands *himself*, the information that *himself* = *John* can also be sent to the interface and the anaphor can be properly interpreted. On the other hand, the embedded v\*P of (18b) is formed as in (20).

(20) [<sub>v\*P</sub> Mary [<sub>v\*</sub> [<sub>VP</sub> recommend himself]]]

In this case, the information on the reference of *himself* cannot be sent to the interface along with the shaded VP because there is no proper antecedent in the structure. Thus, the anaphor fails to be interpreted.

Quicoli's proposal has a wide empirical coverage. However, there are also potentially problematic cases as I discussed in Saito (2017). One of them concerns the absence of the NIC effect in languages without  $\phi$ -feature agreement. Quicoli's theory correctly rules out (21), which is a typical example of this effect.

(21) \*John thinks [<sub>CP</sub> that [<sub>TP</sub> himself will be nominated]]

When the embedded CP is completed, its complement TP is transferred to the C-I interface. The reference of *himself* cannot be determined at this point, and consequently, the reflexive fails to receive an interpretation. However, as Huang (1982) and Yang (1983) point out, the counterparts of (21) in languages without  $\phi$ -feature agreement are grammatical. The following Japanese examples illustrate this:

(22) a. Taroo-wa [<sub>CP</sub> [<sub>TP</sub> zibun-zisin-ga suisens-are-ru] to] omot-te i-ru  
 Taroo-TOP self-self-NOM nominate-Passive-Pres. that think-Pres.

'Taroo thinks that he himself will be nominated.'

b. Hanako-wa [<sub>CP</sub> [<sub>TP</sub> zibun-zisin-ga sore-o mi-ta] to] syutyoosi-ta  
 Hanako-NOM self-self-NOM it-ACC see-Past that claim-Past

'Hanako claimed that she herself saw it.'

Given Chomsky's (2000) definition of phases and transfer domains, Quicoli's theory incorrectly rules out these examples in the same way as (21).

It is already observed in Chomsky (1981) that in English too, an anaphor in the embedded subject position can have an antecedent in the matrix clause when the embedded clause lacks  $\phi$ -feature agreement. Some examples are shown in (23).

(23) a. John prefers [<sub>CP</sub> for [<sub>TP</sub> himself to be nominated]]

b. They want very much [<sub>CP</sub> for [<sub>TP</sub> each other to succeed]]

It seems then that what is transferred at the completion of CP without  $\phi$ -feature agreement is not TP but *v\*P* in the exclusion of the subject. This will allow (22b), for example, as illustrated in (24).

(24) a. [<sub>CP</sub> [<sub>TP</sub> zibun-zisin-ga [<sub>v\*P</sub> sore-o mita]] to]

b. [<sub>v\*P</sub> Hanako [<sub>VP</sub> [<sub>CP</sub> [<sub>TP</sub> zibun-zisin-ga [<sub>v\*P</sub> ...]] to] syutyoosi]]



When the embedded CP is completed as in (24a), the shaded  $v^*P$  is transferred. The embedded subject is transferred later upon the completion of the matrix  $v^*P$ , shown in (24b). *Hanako* is in the structure at this point, and hence, the information, *zibun-zisin = Hanako*, can be sent to the C-I interface.

Saito (2017), with this consideration, proposes (25), building on Chomsky's (2008) idea that T and V inherit  $\phi$ -features from C and  $v^*$  respectively.<sup>1</sup>

- (25) a. T/V inherits phasehood from C/ $v^*$  together with  $\phi$ -features.
- b. A phase HP is transferred upon the completion of the next phase up.

(25) makes the same predictions as Chomsky's (2000) standard theory when there is  $\phi$ -feature agreement. For example, when T inherits  $\phi$ -features from C, TP becomes a phase and is transferred upon the completion of CP, as shown in (26a).

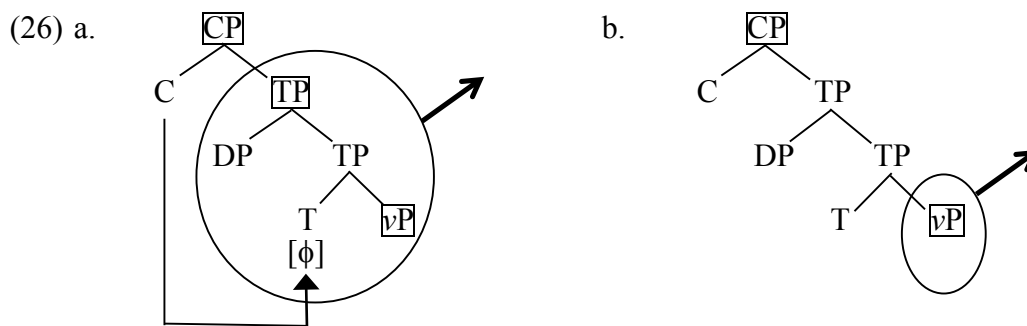

But (25) yields a different result from Chomsky (2000) when there is no  $\phi$ -feature agreement between T and the subject, as shown in (26b). T does not inherit  $\phi$ -features from C, and hence TP is not a phase. Then, what is transferred upon the completion of CP is not TP but  $v^*P$ .

(25) has various consequences as discussed in Saito (2017). Here, I introduce one of them and refer the reader to Saito (2017) for the rest. Chomsky (2000, 2008) maintains that CP and  $v^*P$  are phases because of their interpretive properties.  $v^*P$  is a unit that represents a complete predicate-argument structure and CP is a larger complete unit with Tense and force. Given this, Legate (2003) and Bošković (2016) point out that one would expect unaccusative  $vP$  to be a phase as well. It represents a complete predicate-argument structure just like  $v^*P$ . However, Chomsky does not assume  $vP$  to be a phase because of examples like (27).

- (27) a. The boat sank
  - b.  $[_{TP} \underline{\text{The boat}} [_{TP} T [_{vP} v [_{VP} \text{sink} ]]]]$
- ↑

If  $vP$  is a phase, its complement VP would be transferred to the interpretive components. But

<sup>1</sup> (25b) states that what is transferred is not a phase complement but a phase itself. This is already suggested on independent grounds in Chomsky (2000) and Bošković (2016) although their definitions of phase differ from the one entertained here.

this would make it impossible for *the boat* to move to TP Spec, as can be seen in (27b).

Legates (2003) maintains that  $vP$  is a phase and proposes that the movement in (27b) proceeds through the edge of  $vP$ . However, if (25) is assumed, the movement in (27b) is simply possible and need not be successive-cyclic even if  $vP$  is a phase. An unaccusative  $v$  lacks  $\phi$ -features by definition, and hence, an unaccusative  $V$  does not inherit  $\phi$ -features. Then,  $VP$  in (27b) is not a phase and is not transferred upon the completion of  $vP$ .  $vP$ , being a phase, is transferred when  $CP$  is completed. But the movement takes place prior to this. Thus, if (25) is assumed, there is no reason at all to assume that  $vP$  is not a phase.

### 3.2. Locality of Movement and Binding in Causative Sentence

In this section, I present an analysis of the locality of movement and binding in causative sentences. The analysis provides further evidence for (25).

Let us first consider the anaphor binding example (6b), repeated below as (28).

- (28) Taroo-ga Hanako-ni zibun-zisin-o suisens-ase-ta (koto)  
 Taroo-NOM Hanako-DAT self-self-ACC nominate-make-Past fact

‘Lit. Taroo made Hanako nominate self.’ (zibun-zisin = Taroo or Hanako)

Recall that the matrix subject *Taroo* is a possible antecedent of *zibun-zisin* ‘self-self’ in this example. (28) contrasts with the English (7), repeated in (29).

- (29) John made Bill nominate himself (himself = Bill)

In (29), *John* cannot be the antecedent of *himself*.

The structure of the matrix  $v^*P$  of (28) is shown in (30).

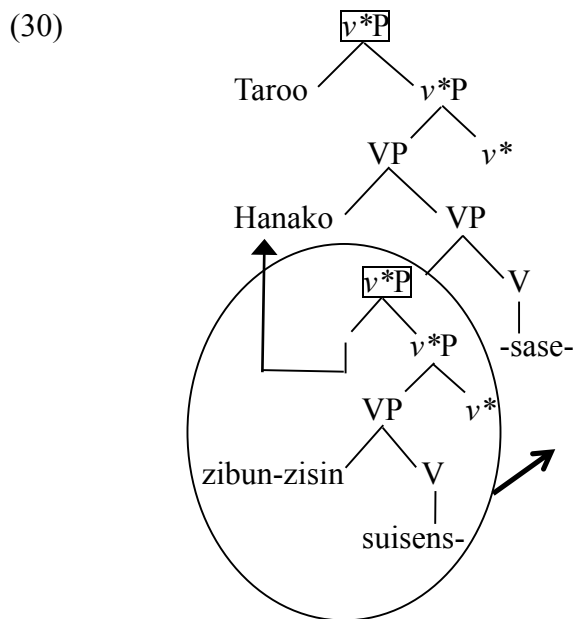

According to (25), the embedded  $v^*P$  phase, which contains *zibun-zisin*, is transferred to the interpretive components upon the completion of the matrix  $v^*P$  phase. And *Taroo* is in the structure, c-commanding *zibun-zisin*, at this point. Hence, it is correctly predicted that *Taroo* can be the antecedent of the anaphor. Note that the standard theory does not yield the desired result. As it states that the complement of a phase head is transferred upon the completion of the phase, the embedded VP is transferred when the embedded  $v^*P$  is completed. Thus, it predicts incorrectly that only *Hanako* can be the antecedent of *zibun-zisin*.

(25) makes the correct prediction also for the English (29). The structure of the embedded  $v^*P$  of this example is shown in (31).

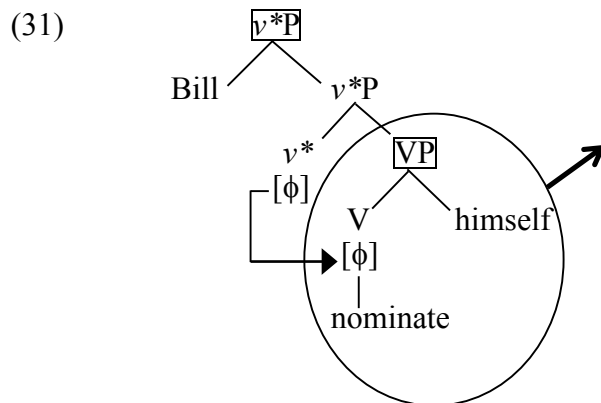

As English is a  $\phi$ -feature agreement language, the verb, *nominate*, inherits  $\phi$ -features and phasehood from  $v^*$ . Then, the VP phase is transferred upon the completion of the embedded  $v^*P$ , as illustrated in (31). The information, *himself* = *Bill*, can be sent to the C-I interface, but *John*, which is yet to enter the structure, is not a possible antecedent for the reflexive. Thus, the interpretation of (29) is accounted for.

Although the interpretation of the reflexive in (28) is as if Japanese causative sentences had simple structures, the passive sentence in (14b), repeated below in (32), is ungrammatical.

(32) \*Wani-ga Hanako-niyotte Taroo-ni \_ tabe-sase-rare-ta  
alligator-NOM Hanako-by Taroo-DAT eat-make-Passive-Past

‘Lit. Alligator meat is such that Hanako made Taroo eat it.’

This is expected given the structure in (30). The basic idea is that the embedded object has to move to the matrix TP Spec but this is impossible because the embedded  $v^*P$  is transferred upon the completion of the matrix  $v^*P$ . The precise account depends on the analysis of Japanese passive, which is controversial. But let us tentatively assume for the purpose of illustration that the passive morpheme, *-rare-*, is a verb that selects a VP complement. Then, the structure of (32) is as in (33).

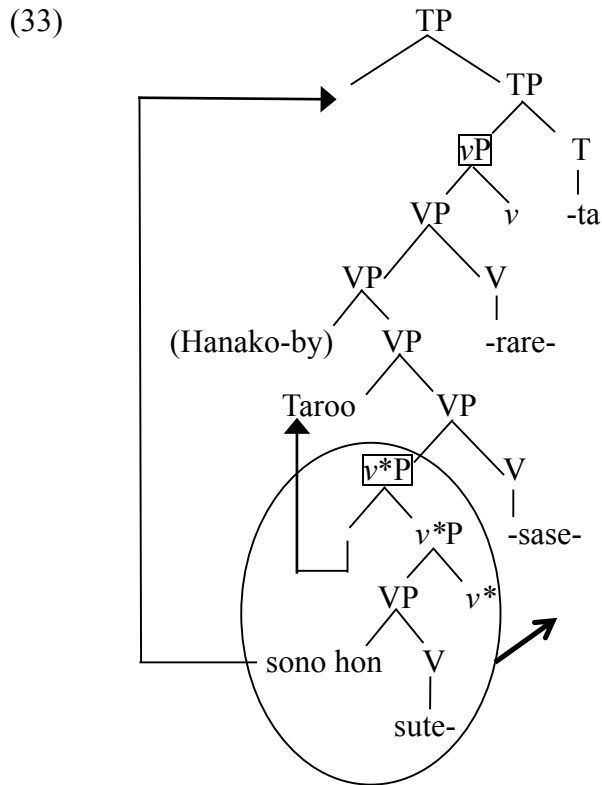

There are two phases,  $vP$  and  $v^*P$  in this structure. When the former is completed, the latter, which contains *sono hon*, is transferred. The noun phrase, therefore, cannot raise to TP Spec.<sup>2</sup>

In this section, I argued that the apparent inconsistency in the locality of binding and movement in Japanese causative sentences is explained by the theory of phase and transfer. It was crucial in the analysis that phases, and not complements of phase heads, are transferred. Causatives in Japanese and English exhibit different patterns with the locality of anaphor binding though their structures are basically identical. I argued that this also follows if  $\phi$ -feature inheritance makes TPs and VPs phases. Overall then, the facts discussed in this section constitute evidence for the proposal in (25) on phases and transfer domains.

#### 4. The Single Accusative Effect

The example of the single accusative effect, (4b), is repeated in (34) with its structure in (35).

- (34) Hanako-ga Taroo-ni/\*-o wani-o tabe-sase-ta (koto)  
 Hanako-NOM Taroo-DAT/-ACC alligator-ACC eat-cause-Past fact  
 ‘Hanako made Taroo eat alligator meat.’

<sup>2</sup> This analysis implies that the NP-movement cannot proceed through the edge of  $vP$ . I tentatively assume here that this is because the edge of  $vP/v^*P$  counts as an A'-position unless it is a  $\theta$ -position.

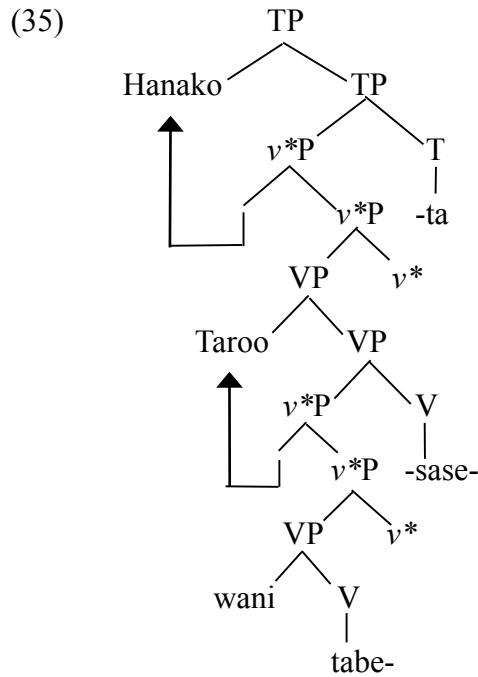

It is generally assumed that  $v^*$  values accusative Case. Then, given the structure in (35), the higher  $v^*$  should be able to value accusative on *Taroo* and the lower  $v^*$  that on *wani* ‘alligator’, yielding (34) with an accusative causee.

An insightful discussion on this problem is found in Takahashi (2010). He argues that *-sase-* absorbs the Case of the lower  $v^*$ . As the result, only the higher  $v^*$  retains the ability to value accusative Case and hence, only one argument can appear in accusative. The remaining question, then, is why this Case absorption takes place. I suggest in this section that this is because the causative morpheme pair-merges with the embedded  $v^*$  before they enter into the larger structure. The account employs the mechanism proposed in Epstein, Kitahara and Seely’s (2016) analysis of examples with unergative verbs that take CP complements. In Section 4.1, I briefly go over Chomsky’s (2013, 2015) proposals on labeling, which form the background of their discussion. Then, in Section 4.2, I introduce Epstein, Kitahara and Seely’s (2016) analysis and present an account of the single accusative effect.

#### 4.1. Weak Heads in Labeling

Epstein, Kitahara and Seely (2016) develop Chomsky’s (2013, 2015) labeling theory. I go over the initial proposals on labeling in Chomsky (2013) first, and then, its extension to explain the EPP in Chomsky (2015).

Phrase structure is formed by the operation Merge, which takes two elements,  $\alpha$  and  $\beta$ , and forms the constituent  $\gamma = \{\alpha, \beta\}$ . Chomsky (2013) proposes a labeling algorithm that determines the nature of  $\gamma$  on the premise that the interpretive components require this information. For example, if  $\alpha$  is verbal and  $\beta$  is nominal, the C-I interface needs to know whether  $\gamma$  is a VP or an NP. The three cases of Merge are shown in (36).

- (36) a.  $\gamma = \{H, XP\}$   
 b.  $\gamma = \{XP, YP\}$   
 c.  $\gamma = \{H_1, H_2\}$

A head and a phrase are merged in (36a), two phrases in (36b), and two heads in (36c). (36a) is the straightforward case. As search into  $\gamma$  finds a unique head H, it can be assumed that H determines the label (nature) of  $\gamma$ . Merge of V and NP, for example, yields a VP. On the other hand, it is impossible to specify a unique label provider in the cases of (36b) and (36c). These structures, then, should be illicit.

However, Chomsky (2013) notes that the configuration in (36b) occurs in simple sentences. Let us consider the derivation of a sentence with a transitive verb in (37).

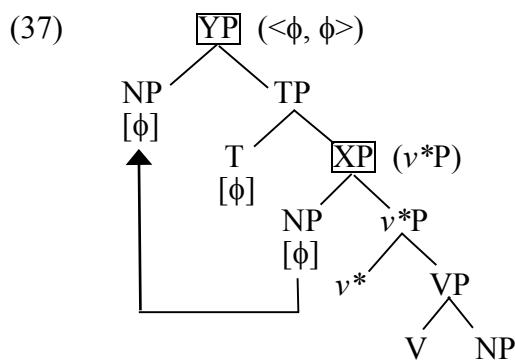

Merge forms the structure from the bottom as  $\{V, NP\} = VP$ ,  $\{v^*, VP\} = v^*P$ . These are instances of (36a) and no problem arises with labeling. Then, the external argument is merged with  $v^*P$ , and  $\{NP, v^*P\} = XP$  fails to be labeled. However, NP moves out of this constituent after T is introduced into the structure as  $\{T, XP\}$ . Chomsky (2013) hypothesizes that  $v^*P$  is the only element that XP fully contains at this point and hence, qualifies to provide the label for XP. The moved NP merges with TP at the top of the structure, and creates the configuration in (36b) again. For this, Chomsky proposes that search into  $\{NP, TP\}$  yields two heads N and T that share the same  $\phi$ -features,  $\phi$ , because of agreement, and this makes it possible to label  $\{NP, TP\}$  as  $\langle\phi, \phi\rangle$ .

This labeling theory places heavy constraints on phrase structure. The basic form that is allowed is  $\{H, XP\}$ . The  $\{XP, YP\}$  structure is allowed in two exceptional contexts. One is when XP moves out of the constituent and the other is when X and Y share a significant feature. This provides an explanation for why phrase structure fits the X' schema. The labeling theory also explains other generalizations, including those on the distribution of noun phrases and the last resort nature of movement.

Chomsky (2015) tries to extend the range of phenomena further that the labeling theory covers. For example, he takes up is the EPP, which requires that the specifier position of TP be filled. (38a) is ungrammatical though the unaccusative *sink* does not take an external argument.

- (38) a. \*Sank two ships  
 b. Affondarono due navi  
 sank two ships  
 c. Two ships sank \_

Interestingly, the Italian counterpart of (38a), shown in (38b), is grammatical. Further, (38a) becomes grammatical if the internal argument moves to TP Spec, as in (38c). This suggests that the TP Spec position needs to be filled in English but not in Italian. That is, Italian but not English allows the clausal structure in (39a).



The structure in (39a) is  $\gamma = \{T, vP\}$ , and there should not be a problem with labeling. But as it is illicit in English, Chomsky proposes that T in English is a weak head, that is, a head that is unable to provide a label. Then, how are tensed clauses labeled in English? Once an NP that agrees with T is raised to TP Spec, the clause is labeled as  $\langle\phi, \phi\rangle$ , as illustrated in (39b). This explains why an element in TP Spec is required in English. Chomsky assumes that the  $\phi$ -feature sharing between N and T makes the latter a strong head, and  $\gamma$  is labeled by T in (39b). But the important point is that  $\phi$ -feature sharing makes labeling of the tensed clause,  $\delta$ , possible.

In (39b), an NP raises to the specifier position of the head that agrees with it and values its Case. Chomsky (2015) generalizes this to transitive verbs and their objects on the premise that the relation of V and the object is parallel to that of T and the subject.<sup>3</sup> In the remainder of this section, I briefly go over his analysis. (40) is the proposed structure of  $v^*P$ .

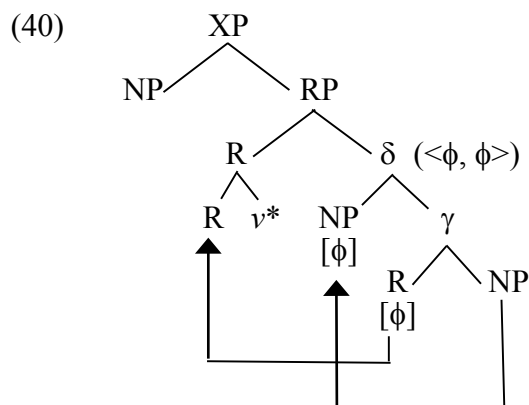

R is the root to be categorized as a verb by  $v^*$ .

<sup>3</sup> There is clear evidence for the movement of the ECM subject to the specifier position of the matrix verb, as discussed, for example, in Lasnik and Saito (1991). Chomsky's motivation is also to generalize this movement to thematic objects.

The assumption here is that R is a weak head just like T. Because of this,  $\gamma$  initially cannot be labeled. The object raises to the specifier position of R, and then  $\delta$  is labeled  $\langle \phi, \phi \rangle$  as R and the NP share  $\phi$ -features. R raises to  $v^*$  and creates a structure where  $v^*$  is pair-merged (adjoined) to R. This makes R categorized as V and  $\langle R, v^* \rangle$  a strong head.

#### 4.2. Pair-Merge of Heads in Derivation

Chomsky's (2015) analysis in terms of weak heads is not fully worked out, and it requires refinements. Epstein, Kitahara and Seely (2016) consider examples with unergative verbs that take CP complements as in (41).

- (41) a. John thinks that Mary is the most qualified candidate  
 b. It seems that Mary is the most qualified candidate

The structure of the matrix  $v^*P$  of (41a), for example, is as in (42).

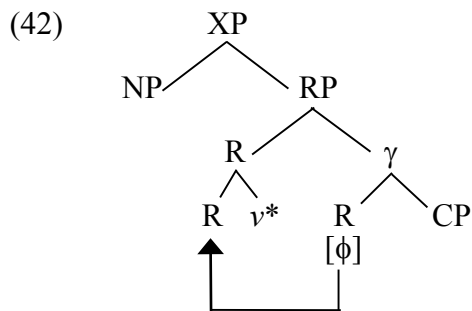

There are a couple of problems with this structure. First, the  $\phi$ -features of R cannot be valued as R does not enter into agreement relation with any NP. Secondly, there is a labeling issue with  $\gamma = \{R, CP\}$ . R, being a weak head, cannot provide the label. Further, movement of CP to the Spec position of R does not help because R and C do not share  $\phi$ -features.

In order to solve these problems, Epstein, Kitahara and Seely (2016) propose that the pair-merge of R and  $v^*$  takes place before these heads enter the larger structure. (42) is revised as (43).

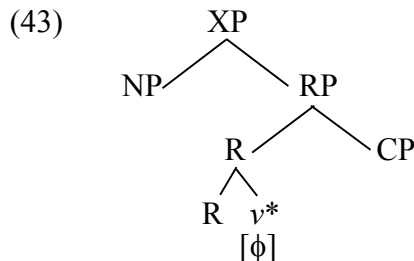

First,  $\langle R, v^* \rangle$  is formed, and then, it merges with CP as  $\langle \langle R, v^* \rangle, CP \rangle$ . Epstein, Kitahara and Seely (2016) follow Chomsky (2008) and assume that the  $\phi$ -features originate in the phase head  $v^*$  and is inherited by the complement R. Their proposal is that the  $\phi$ -features are retained by  $v^*$  as there is no configuration of feature-inheritance, and is suppressed because  $v^*$  is pair-



merged with (adjoined to) R. They assume at the same time that  $v^*$  can assign a  $\theta$ -role to the external argument from the pair-merged (adjoined) position. There is no issue with labeling in (43). R is combined with  $v^*$  and is categorized as V. It is therefore a strong head.

Further work would be necessary to properly evaluate Chomsky's analysis of verbal roots as weak heads and Epstein, Kitahara and Seely's analysis of unergatives. But the proposals on the nature of a pair-merge structure of two heads,  $\langle X, Y \rangle$ , seem promising. Specifically, they propose that the  $\phi$ -features of Y is suppressed and Y does not value Case, and yet, Y is still able to assign a  $\theta$ -role from the pair-merged (adjoined) position. For this, similar ideas have been entertained in the literature. One example is the analysis of sentences like (44) in Hoshi (1995) and Saito and Hoshi (2000).

- (44) Hanako-ga Taroo-ni [<sub>NP</sub> toti-no zyooto]-o si-ta/kokoromi-ta  
 Hanako-NOM Taroo-to land-GEN transfer-ACC do-Past/attempt-Past  
 'Hanako transferred/attempted to transfer a piece of land to Taroo.'

As discussed in detail in Grimshaw and Mester (1988), examples of this kind exhibit a syntax-semantics mismatch. *Taroo-ni* 'Taroo-DAT' is assigned the goal  $\theta$ -role by the head noun of the object NP, *zyooto* 'transfer', but appears outside the NP as a clausal argument. In order to account for this and other properties of the construction, Saito and Hoshi (2000) proposed that *zyooto* covertly moves and adjoins to the main verb. (45) is the structure of  $v^*P$  with the control verb *kokoromi* 'attempt'.

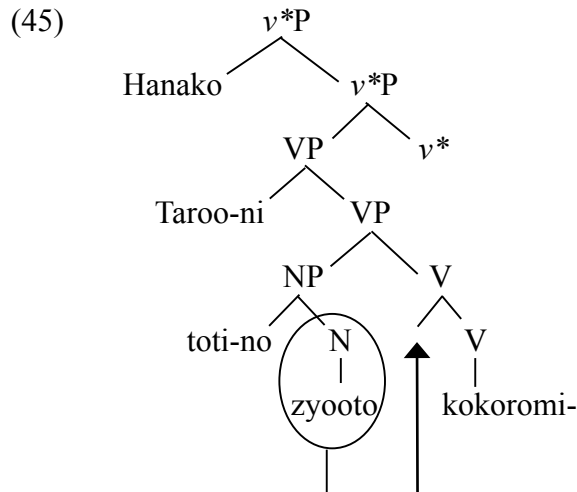

The verb *kokoromi* 'attempt' assigns the theme role to its object NP. The noun *zyooto* 'transfer' assigns the theme role to *toti* 'land' within the NP. It then covertly pair-merges (adjoins) to V and assigns the goal role to *Taroo* from the landing site. This analysis implies that a head can assign a  $\theta$ -role from the pair-merged (adjoined) position. Further, it implies that it is inert at the landing site for Case valuation. The goal argument appears in dative and not in genitive.

Once it is assumed that heads can be pair-merged before they enter into a larger structure,

a slightly different structure for Japanese causative sentences can be entertained.<sup>4</sup> Let us consider again the example in (1) and its structure in (2), repeated below in (46) and (47) respectively.

- (46) Hanako-ga Taroo-ni wani-o tabe-sase-ta  
 Hanako-NOM Taroo-DAT alligator-ACC eat-cause-Past  
 ‘Hanako made Taroo eat alligator meat.’

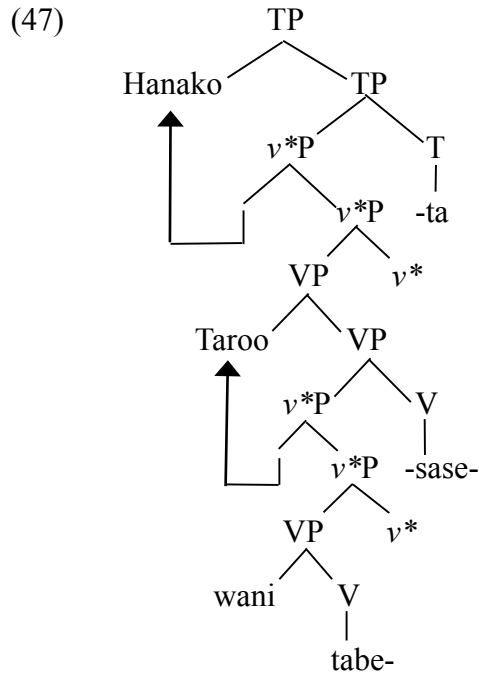

In (47), *Taroo* receives the agent role from *tabe-* ‘eat’ and then moves to receive the causee role from *-sase-* ‘cause’. The movement is redundant if the structure is slightly revised as in (48).

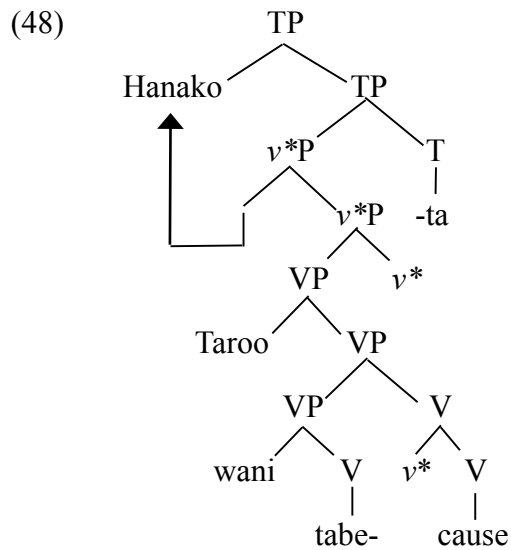

<sup>4</sup> An analysis of Japanese causatives that adopts Epstein, Kitahara and Seely’s pair-merge of two heads is proposed in Nomura (2018). The analysis to be proposed here differs from his but was inspired by it.

Here, the embedded  $v^*$  is pair-merged with (adjoined to) the matrix V directly. As it can assign the agent role to *Taroo* from this position, the NP can receive this  $\theta$ -role and the causee role without movement. The structure has another advantage. That is, the embedded  $v^*$  is inert for Case valuation because it is adjoined to another head, just like the N in (45). Thus, there is only one  $v^*$  that can value accusative Case and the single accusative effect follows.

The remaining question is what prevents the structure in (47), which allows two accusative phrases, and forces that in (48), which does not. Here, I tentatively suggest that the morpheme *-sase-* is a phonetic realization of  $\langle \text{cause}, v^{(*)} \rangle$ . Suppose the Vs and  $v^*$ s in (47) form a compound verb *tabe-sase-* through head-movement (incorporation). Then, first, *tabe-* raises to  $v^*$ , and then, the head complex raises to cause. The resulting structure is as in (49).

(49)  $\langle v^*, \langle \text{cause}, \langle v^*, \text{tabe-}, v^* \rangle \rangle \rangle$

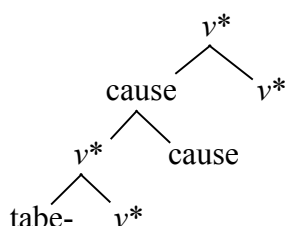

In this structure, there is no unit that exclusively contains the embedded  $v^*$  and cause, and can be lexicalized as *-sase-*. Then, (47) is excluded as the structure for a causative sentence. The only way to form the required unit is to directly merge the embedded  $v^*$  and cause. This forces the structure in (48), and as a result, imposes the restriction that there can be only one accusative argument.

## 5. Conclusion

There is overwhelming evidence that Japanese causative sentences have complex structure with clausal embedding. On the other hand, there are phenomena in which they pattern with simple sentences without embedding. One has to do with the locality of lexical anaphor binding and the other is that those sentences can have at most one accusative argument. I presented an analysis for the former with Quicoli's (2008) phase-based approach to the locality of anaphor binding, incorporating the proposals in Saito (2017) on phases and transfer domains. Then, I suggested an analysis for the latter that is based on Epstein, Kitahara and Seely's (2016) idea that two heads can be directly pair-merged before they enter into a larger structure.

It is challenging to explain the two phenomena considered in this paper with the limited apparatus of the minimalist program. If the approach pursued in this paper is tenable, the phenomena provide important data on the definition of phases and transfer domains, and also on how derivations proceed.

## References

- Bošković, Ž. (2016) “What is sent to Spell-out is Phases, not Phasal Complements,” *Linguistica* 56, 25-56.
- Burzio, L. (1986) *Italian Syntax*, D. Reidel Publishing Company, Dordrecht.
- Chomsky, N. (1981) *Lectures on Government and Binding*, Foris Publications, Dordrecht.
- Chomsky, N. (1986) *Barriers*, MIT Press, Cambridge, Mass.
- Chomsky, N. (2000) “Minimalist Inquiries,” in R. Martin, D. Michaels and J. Uriagereka, eds., *Step by Step: Essays on Minimalist Syntax in Honor of Howard Lasnik*, MIT Press, Cambridge, Mass., 89-155.
- Chomsky, N. (2008) “On Phases,” in R. Freidin, C. P. Otero and M. L. Zubizarreta, eds., *Foundational Issues in Linguistic Theory: Essay in Honor of Jean-Roger Vergnaud*, MIT Press, Cambridge, Mass., 133-166.
- Chomsky, N. (2013) “Problems of Projection,” *Lingua* 130, 33-49.
- Chomsky, N. (2015) “Problems of Projection: Extensions,” in E. Di Domenico, C. Hamann and S. Matteini, eds., *Structures, Strategies and Beyond: Studies in Honour of Adriana Belletti*, John Benjamins, Amsterdam, 3-16.
- Epstein, S., H. Kitahara and D. Seely (2016) “Phase Cancellation by External Pair-Merge of Heads,” *The Linguistic Review* 33, 87-102.
- Grimshaw, J. and A. Mester (1988) “Light Verbs and  $\theta$ -Marking,” *Linguistic Inquiry* 19, 205-232.
- Hoshi, H. (1995) *Passive Verbs and Light Verbs: A Study on Theta Role Assignment*, Ph.D. dissertation, University of Connecticut.
- Huang, C.-T. J. (1982) *Logical Relations in Chinese and the Theory of Grammar*, Ph.D. dissertation, MIT.
- Inoue, K. (1976) *Grammatical Rules in Japanese*, Taishukan, Tokyo. (in Japanese)
- Kato, S. (2016) “Condition (A) and Complex Predicates,” *Nanzan Linguistics* 11, 15-34.
- Kuno, S. (1973) *The Structure of the Japanese Language*, MIT Press, Cambridge, Mass.
- Kuroda, S.-Y. (1965) “Causative Forms in Japanese,” *Foundations of Language* 1, 30-50.
- Lasnik, H. and M. Saito (1991) “On the Subject of Infinitives,” *Proceedings of the Chicago Linguistic Society* 27, 324-343.
- Legate, J. (2003) “Some Interface Properties of the Phase,” *Linguistic Inquiry* 34, 506-516.
- Murasugi, K. and T. Hashimoto (2004) “Three Pieces of Acquisition Evidence for the v-VP Frame,” *Nanzan Linguistics* 1, 1-19.
- Nakamura, M. (1986) *Binding Relations*, Hituzi Syobo, Tokyo. (in Japanese)
- Nomura, Masashi (2018) “Labeling and Pair-Merge of Heads,” presented at *50 years of Linguistics at UConn*, Department of Linguistics, University of Connecticut.
- Oshima, S. (1979) “Conditions on Rules: Anaphora in Japanese,” in G. Bedell, E. Kobayashi, and M. Muraki, eds., *Explorations in Linguistics: Papers in Honor of Kazuko Inoue*, Kenkyusha, Tokyo, 423-448.
- Quicoli, C. (2008) “Anaphora by Phase,” *Syntax* 11, 299-329.
- Saito, M. (2017) “Notes on the Locality of Anaphor Binding and A-movement,” *English Linguistics* 34, 1-33.
- Saito, M. and H. Hoshi (2000) “The Japanese Light Verb Construction and the Minimalist Program,” in R. Martin, D. Michaels and J. Uriagereka, eds., *Step by Step: Essays on Minimalist Syntax in Honor of Howard Lasnik*, MIT Press, Cambridge, Mass., 261-295.

- Shibatani, M. (1976) "Causativization," in M. Shibatani, ed., *Syntax and Semantics 5: Japanese Generative Grammar*, Academic Press, New York, 239-294.
- Takahashi, M. (2010) "Case, Phases, and Nominative/Accusative Conversion in Japanese," *Journal of East Asian Linguistics* 19, 319-355.
- Yang, D.-W. (1983) "The Extended Binding Theory of Anaphors," *Language Research* 19, 169-192.